

INSTALLATION TOOLING

SUPER HLA2008

20° Offset Ratchet Wrench Driver Assembly
with Flush Socket
and Super-Key™ (T-Series)

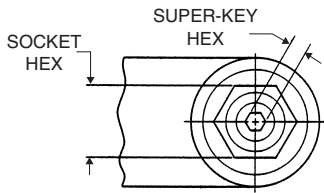
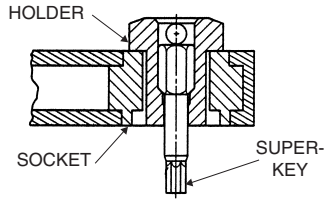

SOCKET END DETAIL

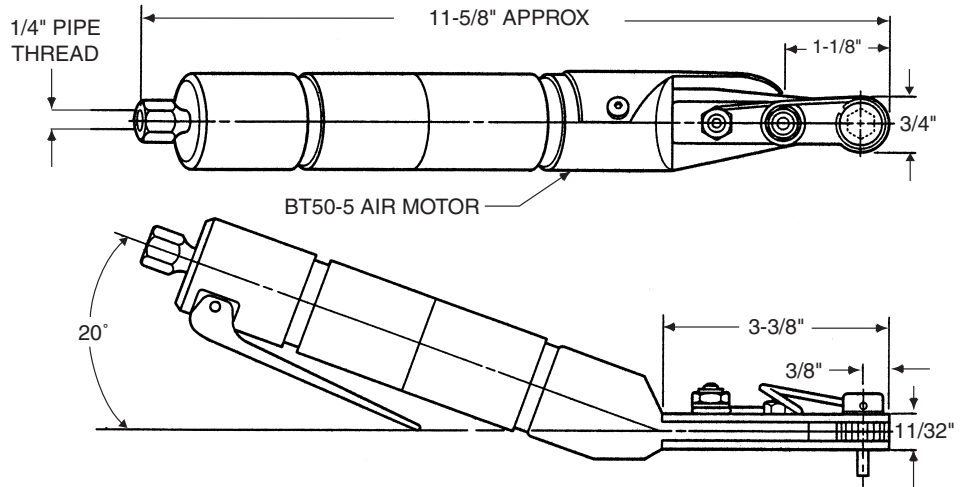

TECHNICAL DATA

| | | | |
|---------------------------------|-------------------|-------------------------|---------|
| Operating Pressure | 90 PSIA | Horsepower Rating | 0.50 |
| MAX. TORQUE RATING | 110 in. lb | Air Consumption | 22 SCFM |
| (Motor) | @ 90 PSIA | Weight | 2 lb |
| Socket Speed | 250 RPM | | |

TABLE 1

| COLLAR DRIVING HEX (Matches Socket Hex) | PIN RECESS HEX (Matches Super-Key Hex) | COMPLETE DRIVER ASSY. PART NO. | OFFSET ADAPTOR & SOCKET ASSY. PART NO. |
|--|---|-----------------------------------|---|
| 3/16 | 1/16 | HLA2008-187-062T | HLR255-187-062T |
| 7/32 | | HLA2008-218-062T | HLR255-218-062T |
| 1/4 | | HLA2008-250-062T | HLR255-250-062T |
| 9/32 | | HLA2008-281-062T | HLR255-281-062T |
| 5/16 | | HLA2008-312-062T | HLR255-312-062T |
| 11/32 | | HLA2008-343-062T | HLR255-343-062T |
| 7/32 | 5/64 | HLA2008-218-078T | HLR255-218-078T |
| 1/4 | | HLA2008-250-078T | HLR255-250-078T |
| 9/32 | | HLA2008-281-078T | HLR255-281-078T |
| 5/16 | | HLA2008-312-078T | HLR255-312-078T |
| 11/32 | | HLA2008-343-078T | HLR255-343-078T |
| 3/8 | | HLA2008-375-078T | HLR255-375-078T |
| 5/16 | 3/32 | HLA2008-312-094T | HLR255-312-094T |
| 11/32 | | HLA2008-343-094T | HLR255-343-094T |
| 3/8 | | HLA2008-375-094T | HLR255-375-094T |
| 7/16 | | HLA2008-437-094T | HLR255-437-094T |
| | | | |

DRIVER BASIC PART NO.

SOCKET HEX REF. TABLE 1

SUPER-KEY HEX REF. TABLE 1

SUPER-KEY (T-SERIES)

HLA2008-312-078T

Example: complete driver assy. part no.

ORDERING INFORMATION

1. Match pin and collar hexes with Super-Key Hex and Socket Hex.
2. See table 1 for corresponding complete driver assy part no.

SUPER HLA2008
20° OFFSET RATCHET WRENCH DRIVER ASSY w/Flush Socket & Super-Key™ (T-Series)



HLR255

20° Offset Ratchet Wrench Attachment Assembly with Flush Socket and Super-Key™ (T-Series)

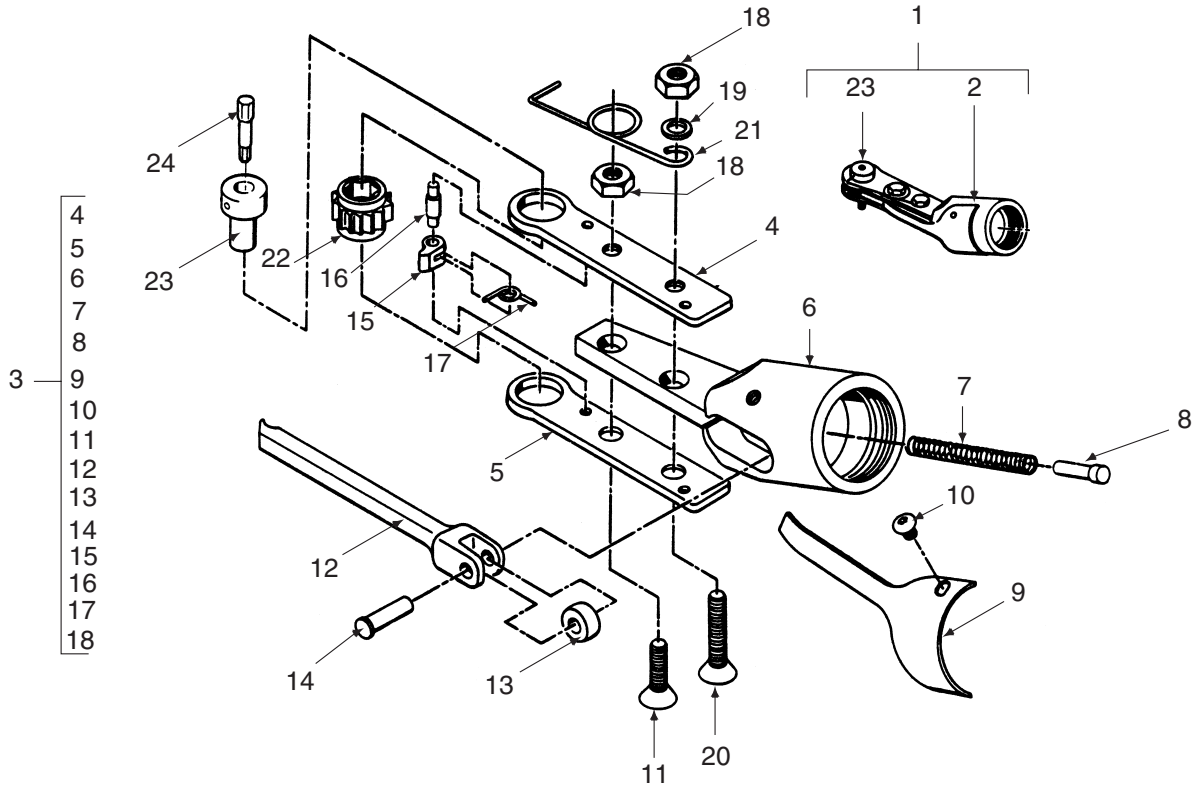

TABLE 2

SOCKET

| HEX SIZE (Matches Collar Driving Hex) | PART NO. |
|---|-------------|
| 3/16 | 537224 |
| 7/32 | 537225 |
| 1/4 | 28543 |
| 9/32 | 28544 |
| 5/16 | 28545 |
| 11/32 | 28547 |
| 3/8 | 28548 |
| 7/16 | 28550 |

TABLE 3

SUPER-KEY

| HEX SIZE (Matches Pin Recess Hex) | PART NO. |
|---|-------------|
| 1/16 | HLT140K-062 |
| 5/64 | HLT140K-078 |
| 3/32 | HLT140K-094 |

| ITEM | PART NO. | DESCRIPTION | QTY |
|------|----------------------|---------------------------------|-----|
| 1 | HLR255-()-()T | Ratchet wrench attachment assy. | 1 |
| 2 | HLR258-() | . Ratchet attachment assy. | 1 |
| 3 | 502914 | .. Ratchet attachment sub-assy. | 1 |
| 4 | 9D-6433 | ... Sideplate, tapped | 1 |
| 5 | 9D-6434 | ... Sideplate, countersunk | 1 |
| 6 | 502915 | ... Housing | 1 |
| 7 | 9D-5163 | ... Spring | 1 |
| 8 | 9D-5159 | ... Pin | 1 |
| 9 | 15680 | ... Cover | 1 |
| 10 | B-117-J | ... Screw | 2 |
| 11 | B-124-A | ... Screw | 1 |
| 12 | A-9D-6432 | ... Pushrod | 1 |
| 13 | 9D-5162 | ... Roller | 1 |
| 14 | 9D-5164 | ... Pin | 1 |
| 15 | 9D-6431 | ... Pawl | 1 |
| 16 | 9D-6430 | ... Pin | 1 |
| 17 | 9D-5161 | ... Spring | 1 |
| 18 | C-101-D | ... Nut | 2 |
| 19 | AN960-416 | .. Washer | 1 |
| 20 | 1/4-20 UNC x 3/4 lg. | .. Screw, flat head socket cap | 1 |
| 21 | HLB-1474-3 | .. Spring | 1 |
| 22 | Table 2 | .. Socket | 1 |
| 23 | HLB138-() | .. Holder | 1 |
| 24 | HLT140K-() Table 3 | .. Super-Key | 1 |