

GB704

SERIES INSTALLATION TOOL

GB704

Stroke - .540" (13.72 mm)
 Tool weight - 4.30 lbs. (1.95 kg)
 Pull load - 3,300 (14.68 kN)

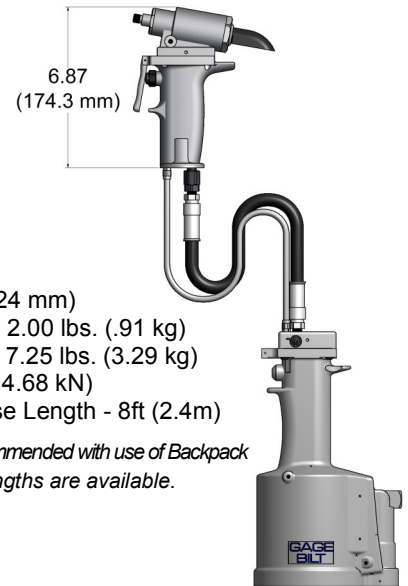
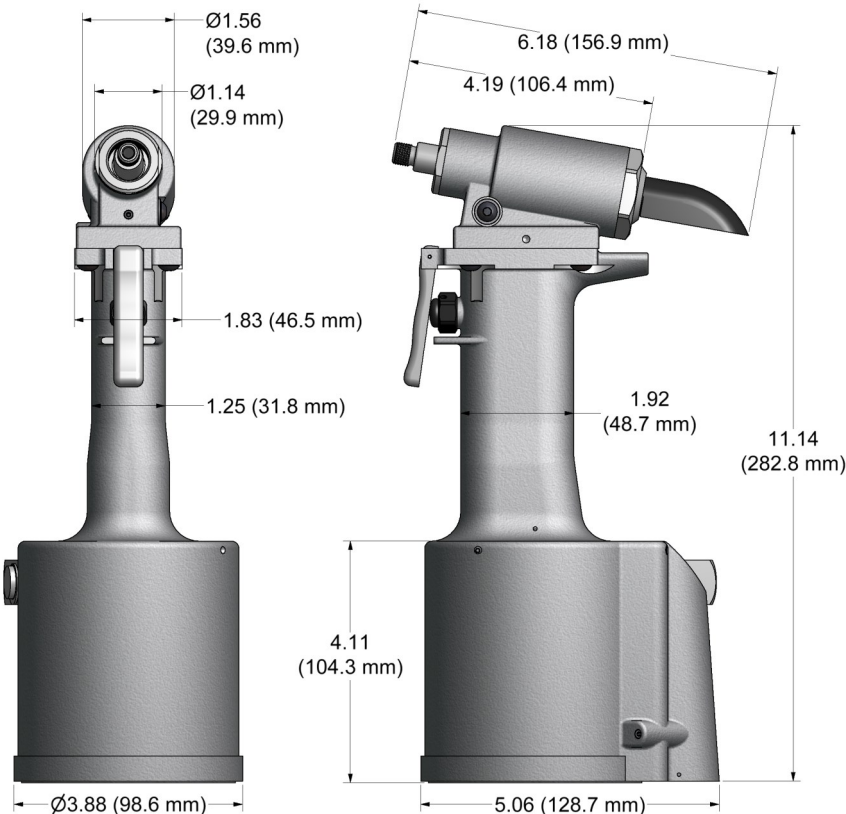

GB704SH

Stroke - .600" (15.24 mm)
 Hand held weight - 2.00 lbs. (.91 kg)
 Entire tool weight - 7.25 lbs. (3.29 kg)
 Pull load - 3,300 (14.68 kN)
 Standard Hyd. Hose Length - 8ft (2.4m)

*5ft Hyd. Hoses are recommended with use of Backpack
 Additional custom lengths are available.*

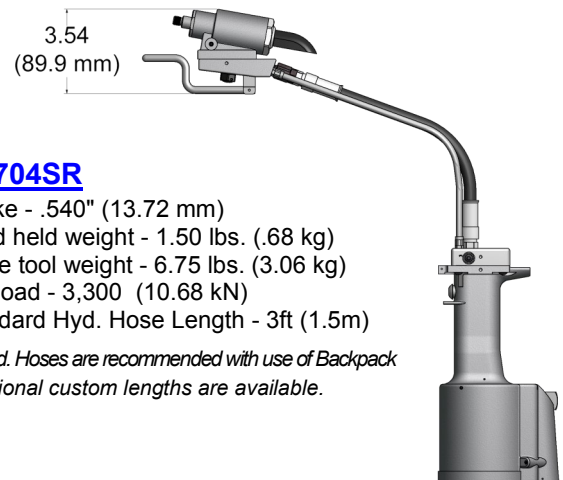

GB704SR

Stroke - .540" (13.72 mm)
 Hand held weight - 1.50 lbs. (.68 kg)
 Entire tool weight - 6.75 lbs. (3.06 kg)
 Pull load - 3,300 (10.68 kN)
 Standard Hyd. Hose Length - 3ft (1.5m)

*5ft Hyd. Hoses are recommended with use of Backpack
 Additional custom lengths are available.*

DESCRIPTION

The GB704 series are pneumatic-hydraulic tools designed specifically for the efficient installation of blind rivets. They can be operated in any position. They have a rated pull load of 3,300 lbs (14.68 kN) with 90 psi (6.2 bar) air pressure at the air inlet.

The GB704SH and GB704SR riveters offer a unique "split" system providing the operator with an ergonomic tool with reduced hand held weight. The GB704SH comes with 8 feet (2.4 m) of hose and the GB704SR comes with 3 feet (1.5 m) of hose. Use with our "NEW" Split-System Backpacks to increase user mobility, ergonomics and productivity. Contact GAGE BILT for more information.

The GB704 series riveters operate on 90 to 100 psi (6.2-6.9 bar) of air pressure, with 90 psi (6.2 bar) providing the maximum efficiency. At 90 psi (6.2 bar) of air pressure, the GB704 & GB704SR do not exceed 81.5 dB(A) and consume .16 SCF/cycle (4.53 L/cycle). The GB704SH consumes .30 SCF/cycle (8.50 L/cycle).

The air inlet is provided with 1/4-18 female pipe thread to accept the users air hose fitting.

NOSE ASSEMBLIES ARE NOT FURNISHED WITH TOOL AND MUST BE ORDERED SEPARATELY.

GAGE BILT
 **MADE in USA**

44766 Centre Court Clinton Twp. MI 48038 USA
 Ph: +1 (586) 226-1500 Fax: +1 (586) 226-1505
solutions@gagebilt.com / www.gagebilt.com

ACCESSORIES AND RIVETER KITS

GB704 NOSE ASSEMBLY SELECTION CHART

Catcher Bag-Stem
#704214
 (Sold Separately)



Air Bleeder Assy
#704153
 (Sold Separately)



RIVETER KIT
#GB704RK
 (Sold Separately)



RIVETER KIT
#GB704RK-1
 (Sold Separately)



STRAIGHT
 (Sold Separately)

RIGHT ANGLE
 (Sold Separately)

OFFSET
 (Sold Separately)

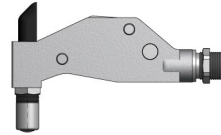
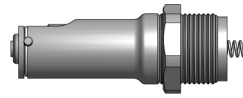

FASTENER	DIAMETER	STRAIGHT	RIGHT ANGLE (2)	OFFSET
CHERRYMAX®, CHERRYMAX® 'AB', MBC® LOCK CREATOR	1/8 5/32 3/16	456MAX-701-17 (1) 456MAX-704-35 (1) 456MAX-749-35 (3, 1)	456MAX-704-54RA (1)	456MAX-704-43OS (1)
NUT PLATE RIVETS MS20600 SERIES CCR244/264/274 MS/9SP/PT BACR15CC/CF/DADR	3/32 1/8 5/32 3/16	3C-704A-16 4C-704A-16 5C-704A-16 6C-704A-16	3C-704-54RA 4C-704-54RA 5C-704-54RA 6C-704-54RA	3C-704A-40OS 4C-704A-40OS 5C-704A-40OS 6C-704A-40OS
'A' CODE NAS1398A NAS1399A	3/32 1/8 5/32 3/16	3A-704A-16 4A-704A-16 5A-704A-16 6A-704A-16	3A-704-54RA 4A-704-54RA 5A-704-54RA 6A-704-54RA	3A-704A-40OS 4A-704A-40OS 5A-704A-40OS 6A-704A-40OS
GROUND STUD M83454 BACS53B1EA1/2	8/32 10/32	GS8-704-16 GS10-704A-19	GS8-704A-54RA GS10-704-54RA	GS8-704-40OS GS10-704A-40OS

CHERRYMAX® and MBC® are registered trademarks of Cherry Aerospace Fasteners.

GAGE BILT CERTIFIES THE GB704 WILL INSTALL THE ABOVE FASTENERS

- 1) INSTALLS 1/8", 5/32", AND 3/16" DIAMETERS
- 2) RIGHT ANGLE NOSE ASSEMBLIES MAY REQUIRE MORE THAN ONE PULL
- 3) FRONT END EJECTING NOSE ASSEMBLY.

NOTE: THE LAST 2 DIGITS OF THE NOSE ASSEMBLY REPRESENTS THE LENGTH THE NOSE EXTENDS FROM THE TOOL I.E. -20 = 2.0 INCHES

8/18

Grip Gage #GB105093

For NAS LOCKBOLTS and blind fasteners
 (Sold Separately)



Grip Gage #269G3

For CHERRYMAX® and CHERRYLOCK® rivets
 (Sold Separately)

