

# GB713

## PNEUDRAULIC INSTALLATION TOOL SERIES

# GAGE BILT

INNOVATIVE  
RIVET & LOCKBOLT TOOLS

44766 Centre Ct. Clinton Twp. MI 48038 USA

+1 586. 226. 1500

+1 586. 226. 1505

[solutions@gagebilt.com](mailto:solutions@gagebilt.com)

[www.gagebilt.com](http://www.gagebilt.com)

### GB713

Stroke - .760" (19.3mm)  
Tool weight - 6.50 lbs. (2.9 kg)  
Pull load - 4,500 (20.0 kN)

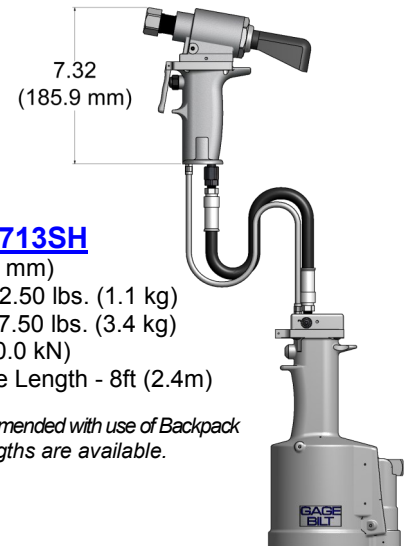
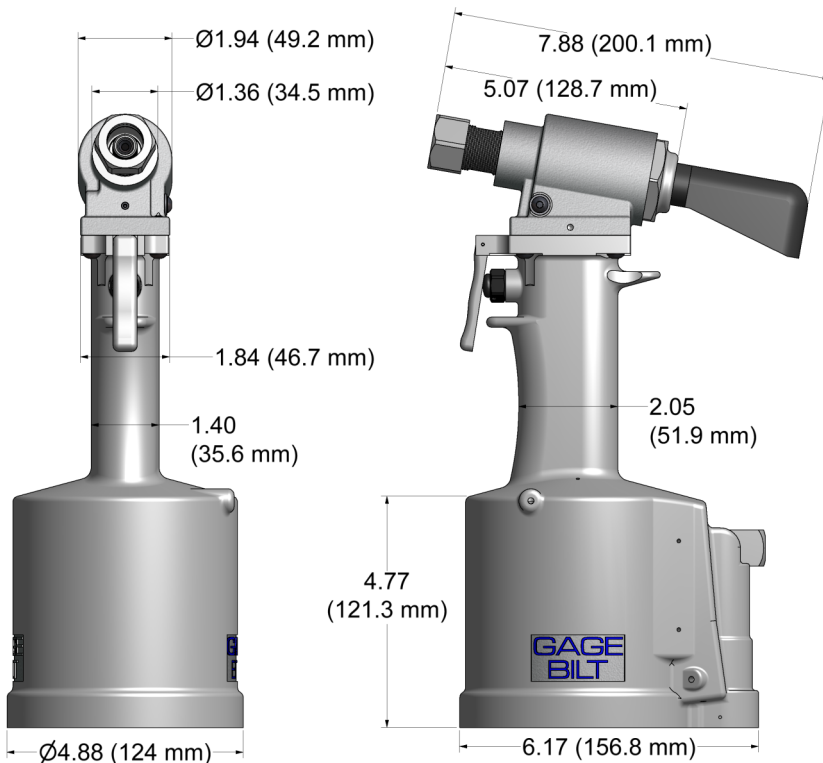

### GB713SH

Stroke - .760" (19.3 mm)  
Hand held weight - 2.50 lbs. (1.1 kg)  
Entire tool weight - 7.50 lbs. (3.4 kg)  
Pull load - 4,500 (20.0 kN)  
Standard Hyd. Hose Length - 8ft (2.4m)

*5ft Hyd. Hoses are recommended with use of Backpack  
Additional custom lengths are available.*

### GB713SR

Stroke - .760" (19.3 mm)  
Hand held weight - 2.00 lbs. (0.9 kg)  
Entire tool weight - 7.00 lbs. (3.2 kg)  
Pull load - 4,500 (20.0 kN)  
Standard Hyd. Hose Length - 3ft (1.m)

*5ft Hyd. Hoses are recommended with use of Backpack  
Additional custom lengths are available.*

The GB713 series are pneumatic-hydraulic tools designed specifically for the efficient installation of blind rivets and lockbolt fasteners. It weighs 6.50 lbs. (2.9 kg) and can be operated in any position. It has a .760" (19.3 mm) setting stroke and a rated pull load of 4,500 pounds (20.0 kN) with 90 psi. (6.2 bar) air pressure at the air inlet.

The GB713SH and GB713SR riveters offer a unique "split" system providing the operator with an ergonomic tool with reduced hand held weight. The GB713SH comes with 8 feet (2.4 m) of hose and the GB713SR comes with 3 feet (1 m) of hose. Use with our "NEW" Split-System Backpacks to increase user mobility, ergonomics and productivity. Contact GAGE BILT for more information.

The GB713 series riveter operate on 90 to 100 psi. (6.2-6.9 bar) of air pressure, with 90 psi. (6.2 bar) providing the maximum efficiency. At 90 psi. (6.2 bar) of air pressure, the GB713 series does not exceed 81.5 dB(A) and consumes .30 SCF/cycle (8.50 L/ cycle). The air inlet is provided with 1/4-18 female pipe thread to accept the users air hose fitting.

**NOSE ASSEMBLIES ARE NOT FURNISHED WITH TOOL AND MUST BE ORDERED SEPARATELY.**





# GB713-NOSE ASSEMBLY SELECTION CHART & ACCESSORIES



## ACCESSORIES

**Catcher Bag-Stem**  
#704214  
(Sold Separately)



**Air Bleeder Assy**  
#704153  
(Sold Separately)



### Grip Gage #269G3

For CHERRYMAX®, "A" Code, NAS 1900 series and CHERRYLOCK® rivets  
(Sold Separately)

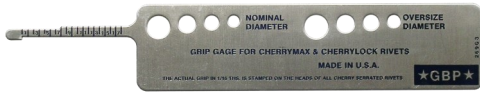

### Grip Gage #GB105093

For NAS LOCKBOLTS and blind fasteners  
(Sold Separately)



Gage Bilt also supplies pin & collar swage inspection gages to certify swage installation.  
(Sold Separately)

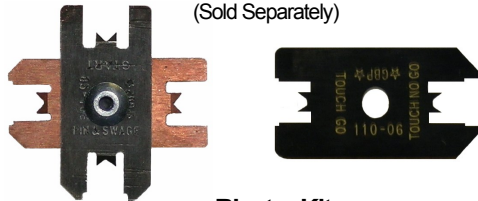

### Riveter Kits

Gage Bilt offers a wide selection of standard and custom kits tailored to your needs  
Contact us for more information.  
(Sold Separately)



## NOSE ASSEMBLIES

**STRAIGHT**  
(Sold Separately)

**RIGHT ANGLE**  
(Sold Separately)

**OFFSET**  
(Sold Separately)

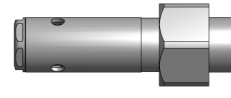

FASTENER	DIA.	STRAIGHT		*RIGHT ANGLE	*OFFSET
C6L® LOCKBOLTS	3/16	LB06-722-20	LB06-722-60		
	1/4	LB08-722-20	LB08-722-60		
MAGNA-GRIP® LOCKBOLTS	3/16	MG06-722-20	MG06-722-60		
	1/4	MG08-722-20	MG08-722-60		
BLIND BOLT (SINGLE ACTION) WITH OR W/OUT DRIVE WASHER MS90353S & U / MS90354S & U MS21140S & U / MS21141S & U MAXI-BOLT®, BACB30YY, YU, & YT	1/8	SB04-752C-20	SB04-752C-45	SB04-751C-54RA 4	SB04-752B-43OS
	5/32	SB05-752C-20	SB05-752C-45	SB05-751C-54RA 4	SB05-752A-43OS
	3/16	SB06-752B-20	SB06-752B-45	SB06-751B-54RA 4	SB06-204D-27OS 3
	1/4	SB08-713-20 3	SB08-713-45 3	SB08-713A-58RA 3	SB08-204D-27OS 3
BLIND BOLT (SINGLE ACTION) WITH DRIVE WASHER MS90353S & U / MS90354S & U MS21140S & U / MS21141S & U CR7000 SERIES, BACB30YY, YU, & YT	1/8	UBB04-752C-20	UBB04-752C-45	UBB04-751C-54RA 4	UBB04-752B-43OS
	5/32	UBB05-752C-20	UBB05-752C-45	UBB05-751C-54RA 4	UBB05-752B-43OS
	3/16	UBB06-752B-20	UBB06-752B-45	UBB06-751B-54RA 4	UBB06-204D-27OS
	1/4	UBB08-713-20 3	UBB08-713-45 3	UBB08-713A-58RA 3	UBB08-204D-27OS 3
EN6122 & UAB130-EU EN6127 & UAB6127-EU EN6128 & UAB100-EU EN6129 & UABP-EU	5/32	UAB568-713-21 5	UAB568-713-61 5		
	3/16			UAB06-751B-54RA 4	UAB06-752B-43OS
BLIND RIVET (SINGLE ACTION) WITH OR W/OUT DRIVE WASHER NAS1900 S & U SERIES	1/8	SMLS04-752C-20	SMLS04-752C-45	SMLS04-751C-54RA 4	SMLS04-752B-43OS
	5/32	SMLS05-752C-20	SMLS05-752C-45	SMLS05-751C-54RA 4	SMLS05-752B-43OS
	3/16	SMLS06-752B-20	SMLS06-752B-45	SMLS06-751C-54RA 4	SMLS06-752B-43OS
	1/4	SMLS08-713-20		SMLS08-713B-58RA 4	SMLS08-752B-43OS 3
"A" CODE NAS1398A & NAS1399A	3/32	3A-352B-25		3A-751C-54RA 4	
	1/8	4A-752C-20	4A-752C-45	4A-751C-54RA 4	4A-752B-43OS
	5/32	5A-752C-20	5A-752C-45	5A-751C-54RA 4	5A-752B-43OS
	3/16	6A-752B-20	6A-752B-45	6A-751C-54RA 4	6A-752B-43OS
T RIVET®	3/16	6T-352-21	6T-352-61		
	1/4	8T-352-21	8T-352-61		
PROTRUDING HEAD, MULTI-GRIP BLIND RIVETS	3/16	MGL06-752A-21	MGL06-752A-61	MGL06-713B-58RA	
	1/4	MGL08-752A-21	MGL08-752A-61	MGL08-713B-58RA	
MONOBOLT®	3/16	MB06-752A-21	MB06-752A-61		
1/4	MB08-752A-21	MB08-752A-61			
CONTAINER BOLT (R 12) HLFP, HLFPA, HLPE, HLPS HLFPC & HLFPM	3/8	HT12-713-20			
TLR RIVET®	1/4	8TLR-352-21	8TLR-352-61		
CHERRYMAX®, CHERRYMAX® AB, BACR15FR/FP, BACR15GF/GK	1/8	456MAX-751-23 1	456MAX-751A-61 1	456MAX-751D-54RA 1,4	456MAX-731-43OS 1
	5/32				
3/16					
1/4	08MAX-752B-20	08MAX-752B-45	08MAX-713A-58RA	08MAX-204D-27OS	08MAX-204D-37OS
ASP® ASP 2, ASP PF, ASP 4 FF, ASP 2 F, ASP 2 LC	13/64	ASP06-752B-20	ASP06-752B-45	ASP06-751B-54RA 4	ASP06-752B-43OS
	17/64	ASP08-752B-20	ASP08-752B-45		ASP08-752B-43OS
	21/64	ASPI0-713-20	ASPI0-713-45		ASPI0-204D-27OS
3/16				ASPI0-204D-37OS	
STANDARD MBC® NAS1719, NAS1720 NAS1721	1/8	MBC04-752C-20	MBC04-752C-45	MBC04-751C-54RA 4	MBC04-752C-43OS
	5/32	MBC05-752C-20	MBC05-752C-45	MBC05-751C-54RA 4	MBC05-752C-43OS
	3/16	MBC06-752B-20	MBC06-752B-45	MBC06-751C-54RA 4	MBC06-752C-43OS
MBC® LOCK CREATOR NAS1719X(L), NAS1720X(L) NAS1721X(L)	1/8				
	5/32	456MAX-751-23 1	456MAX-751A-61 1	456MAX-751D-54RA 1,4	456MAX-731-43OS 1
3/16					
GROUND STUD, M83454 BACS93B	8/32	GS8-752C-20	GS8-752C-45	GS8-751C-54RA 4	GS8-752B-43OS
	10/32	GS10-752B-20	GS10-752B-45	GS10-752A-54RA 4	GS10-752B-43OS
MILLIMETER PLUG SEAL	4mm	5N-751-23	5N-352-61	45N-751B-54RA 4	5N-751A-43OS
	5mm	6N-751-23	6N-352-61	6N-751C-54RA 4	6N-751A-43OS
	5/32	5N-751-23	5N-352-61	45N-751B-54RA 4	5N-751A-43OS
POP® OPEN END NAIL RIVET	3/16	6N-751-23	6N-352-61	6N-751C-54RA 4	6N-751A-43OS
	1/4	8CN-713-21	8CN-713-61	8N-713A-58RA	
POP® CLOSED END NAIL RIVET (ALUMINUM MANDREL)	5/32	5CEA-751-23	5CEA-352-61	5CEA-751B-54RA 4	5CEA-751-43OS
	3/16	6CEA-751-23	6CEA-352-61	6CEA-751C-54RA 4	6CEA-751-43OS
POP® CLOSED END NAIL RIVET (STEEL MANDREL)	5/32	5CES-751-23	5CES-352-61	5CES-751B-54RA 4	5CES-751-43OS
	3/16	6CES-751-23	6CES-352-61	6CES-751C-54RA 4	6CES-751-43OS
1/4			8CES-713A-58RA		

T RIVET®, CHERRYMAX®, MAXI-BOLT®, AND MBC® ARE REGISTERED TRADEMARKS OF CHERRY AEROSPACE. MONOBOLT® AND TLR® ARE REGISTERED TRADEMARKS OF AVDEL UK LIMITED. ASP®, MAGNA-GRIP® AND C6L® ARE REGISTERED TRADEMARKS OF ARCONIC INC.

GAGE BILT CERTIFIES THE GB713 WILL INSTALL THE ABOVE FASTENERS

*ALL OFFSET 204 SERIES NOSES REQUIRE 751204 ADAPTER & 713152 STROKE LIMITER.
1) INSTALLS 1/8", 5/32" AND 3/16" DIAMETERS.
2) ALUMINUM ONLY.
3) 105 P.S.I. REQUIRED FOR MS90353 & MS90354.
4) THESE NOSES REQUIRE 713153 STROKE LIMITER.
5) INSTALLS 5/32", 3/16", AND 1/4"

NOTE: THE LAST 2 DIGITS OF THE NOSE ASSEMBLY REPRESENTS THE LENGTH THE NOSE EXTENDS FROM THE TOOL. IE. -20 = 2.0 INCHES