

GB730

INSTALLATION TOOL SERIES

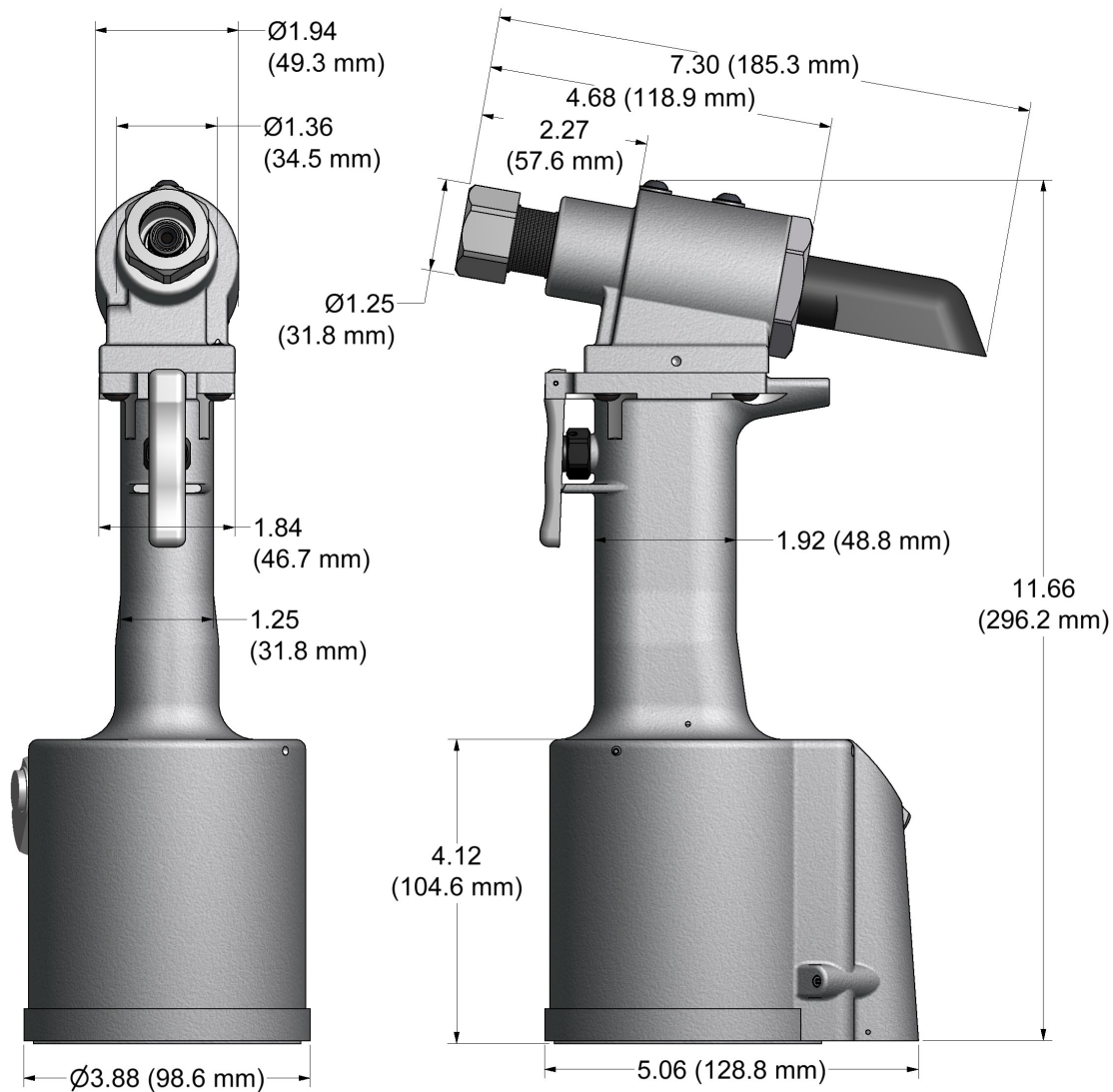

DESCRIPTION

Covered under Patent No. 5,485,727

The GB730 is a pneumatic-hydraulic tool designed specifically for the efficient installation of blind rivets and lockbolts. It weighs just under 4.7 lbs. (2.13 kg) and can be operated in any position. It has a .500" (12.7 mm) rivet setting stroke and a rated pull load of 4,000 lbs (17.79 kN) on 90 psi (6.2 bar) air pressure at the air inlet.

The GB730 riveter operates on 90 to 100 psi (6.2-6.9 bar) of air pressure, with 90 psi (6.2 bar) providing the maximum efficiency. At 90 psi. (6.2 bar) of air pressure, the GB730 does not exceed 81.5 dB(A) and consumes .16 SCF/cycle (4.53 L/cycle).

The air inlet is provided with 1/4-18 female pipe thread for accepting the user's air hose fitting.

NOSE ASSEMBLIES ARE NOT FURNISHED WITH THIS RIVETER AND MUST BE ORDERED SEPARATELY.

GAGE BILT
 **MADE in USA**

44766 Centre Court Clinton Twp. MI 48038 USA
 Ph: +1 (586) 226-1500 Fax: +1 (586) 226-1505
solutions@gagebilt.com / www.gagebilt.com



ACCESSORIES

NOSE ASSEMBLIES

**Catcher Bag-Stem
#731610**
(Sold Separately)



Grip Gage #269G3
For CHERRYMAX® and
CHERRYLOCK® rivets
(Sold Separately)



Grip Gage #GB105093
For NAS LOCKBOLTS and blind fasteners
(Sold Separately)



**Stroke Limiter
#730157**

Required with -54 right angle nose
assy's when used on GB730 tool.
See Chart.
(Sold Separately)



**Stroke Setting Gage
#730703**
(Sold Separately)

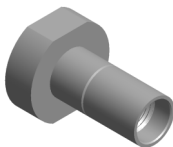

Riveter Kits

Gage Bilt offers a wide selection of standard
and custom kits tailored to your needs.
Contact us for more information.
(Sold Separately)



STRAIGHT
(Sold Separately)



RIGHT ANGLE
(Sold Separately)



OFFSET
(Sold Separately)



FASTENER	DIA.	STRAIGHT	RIGHT ANGLE	OFFSET	
'A' CODE NAS1398 & NAS1399 'A'	3/32 1/8 5/32 3/16 1/4	3A-352B-25 4A-752C-20 5A-752C-20 6A-752B-20 SMLS08-713-20	4A-752C-45 5A-752C-45 6A-752B-45	3A-751C-54RA 4A-751C-54RA 5A-751C-54RA 6A-751C-54RA	4A-752B-43OS 5A-752B-43OS 6A-752B-43OS SMLS08-752B-43OS
ASP® 2 ASP & ASP FF ASP FF & ASP F ASP-LC & MA F	13/64 17/64	ASP06-752C-20 ASP08-752B-20	ASP06-752C-45 ASP08-752B-45	ASP06-751B-54RA ASP08-751B-54RA	ASP06-752B-43OS ASP08-752B-43OS
COMMERCIAL LOCKBOLTS C6L® AVDELOK®	3/16 1/4	LB06-722-20 LB08-722-20			NAS06-204C-25OS NAS08-204C-34OS NAS08-204C-34OS
LGP® LOCKBOLT	5/32	LGP05-2480-10 LGP05-2480-45	LGP05-2480-20		LGP05-204C-25OS LGP05-204C-34OS
LGPL2SC-V LGPL18SC-V LGPL4SC-V LGP2SP-V LGPL4SP-V LGPL8SC-V LGPL9SC-V LGPL9SP-V BACB31N	3/16 7/32	BACB30VM BACB30XT ABS0548 BACB30VN ASNA2392 BACB30WD BACB30WB BACB30VY BACB31P	LGP06-2480-10 LGP06-2480-45 LGP07-731-10 LGP07-731-45		LGP06-204D-30OS LGP06-204C-34OS LGP07-204D-30OS LGP07-204C-34OS
MLGP® (MILLIMETER) LOCKBOLT	4mm 5mm	MLGP4-2480-20 MLGP5-2480-20	MLGP4-2480-45 MLGP5-2480-45		MLGP4-204C-25OS MLGP4-204C-34OS MLGP5-204C-25OS MLGP5-204C-34OS
NAS and GP® SHEAR/TENSION LOCKBOLTS	5/32 3/16	NASS05-2480-10 NASS05-2480-20 NASS05-2480-45 NAS06-2480-10 NAS06-2480-45	NAST05-2480-10 NAST05-2480-20 NAST05-2480-45 NAS06-2480-20	NASS05-204C-25O NASS05-204C-30O NASS05-204C-34O NAS06-204C-25OS NAS06-204C-34OS	NAST05-204C-20O NAST05-204C-30O NAST05-204C-34O NAS06-204D-30OS
BACB30TY BACB30TZ BA CB30DY BACB30DX BACB30GO BACB30GW		BACB30UA BACB30UB BACB30GX BACB30GP BACB30GY			
MGP® (MILLIMETER) LOCKBOLT	4mm 5mm	MGP4-2480-20 MGP5-2480-20	MGP4-2480-45 MGP5-2480-45		MGP4-204C-25OS MGP4-204C-34OS MGP5-204C-25OS MGP5-204C-34OS
CHERRYMAX®, CHERRYMAX® 'AB', BACR15FR/FP, BACR15GF/GK,	1/8 5/32 3/16	456MAX-751-23z	456MAX-751A-61 z	456MAX-751D-54RA z	456MAX-731-43OS z
MBC® LOCK CREATOR NAS1719X(L), NAS1720X(L) NAS1721X(L)	1/8 5/32 3/16	456MAX-751-23z	456MAX-751A-61 z	456MAX-751D-54RA z	456MAX-731-43OS z
NAS1900 S & U SERIES BLIND RIVET WITH DRIVE WASHER BLIND BOLT (SINGLE ACTION) WITH OR W/O DRIVE WASHER	1/4 1/8 5/32	08MAX-752B-20 SMLS04-752C-20 SB05-752C-20	08MAX-752B-45 SMLS04-752C-45 SB05-752C-45	08MAX-713A-58RA SB05-751C-54RA	08MAX-204D-27OS SB05-752A-43OS
MS90353S & U / MS90354S & U MS21140S & U / MS21141S & U MAXI-BOLT®, BACB30YY, YU, & YT	3/16	SB05-752C-80 SB06-752B-20 SB06-752B-80	SB06-752B-45	SB06-751B-54RA	SB06-204D-27OS
EN6122 & UAB130-EU EN6127 & UAB6127-EU EN6128 & UAB100-EU EN6129 & UABP-EU	5/32 3/16 1/4	UAB568-713-21 z	UAB568-713-61 z	UBB06-751B-54RA	UBB06-752B-43OS
BLIND RIVET (SINGLE ACTION) WITH OR W/O DRIVE WASHER NAS1900 S & U SERIES	1/8 5/32 3/16 1/4	SMLS04-752C-20 SMLS05-752C-20 SMLS06-752B-20 SMLS08-713-20	SMLS04-752C-45 SMLS05-752C-45 SMLS06-752B-45	SMLS04-751C-54RA SMLS05-751C-54RA SMLS06-751C-54RA SMLS08-713B-58RA	SMLS04-752B-43OS SMLS05-752B-43OS SMLS06-752B-43OS SMLS08-752B-43OS

ASP®, GP®, C6L®, MGP®, MLGP® AND LGP® ARE REGISTERED TRADEMARKS OF ARCONIC INC. AVDELOK® IS A REGISTERED TRADEMARK OF AVDEL UK LIMITED. CHERRYMAX®, MAXI-BOLT®, AND MBC® ARE REGISTERED TRADEMARKS OF CHERRY AEROSPACE FASTENERS.

GAGE BILT CERTIFIES THE GB730 WILL INSTALL THE ABOVE FASTENERS.

*ALL RIGHT ANGLE NOSES REQUIRE 730157 STROKE LIMITER EXCEPT 58RA.
*ALL OFFSET 204 SERIES NOSES REQUIRE 751204 ADAPTER.
1) RIGHT ANGLE NOSE ASSEMBLY'S MAY REQUIRE MORE THAN ONE PULL.
2) INSTALLS 1/8, 5/32 & 3/16 DIAMETERS
3) ALUMINUM ONLY
4) INSTALLS 5/32, 3/16, & 1/4 DIAMETERS

NOTE: THE LAST 2 DIGITS OF THE NOSE ASSEMBLY REPRESENTS THE LENGTH THE NOSE EXTENDS FROM THE TOOL. I.E. -20 = 2.0 INCHES

Rev. 6/18

**Adapter Assy
#751204**

Adapts 204 offset series nose
assemblies to GB730 installation tool.
(Sold Separately)



Other adapters available. Contact
Gage Bilt for more information.

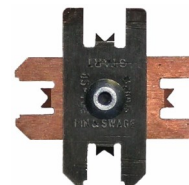

Gage Bilt also supplies
pin & collar swage
inspection gages to
certify swage
installation.
(Sold Separately)



Rev. 6/18