

GB784

SERIES INSTALLATION TOOL

GB784

Stroke - .875" (22.2 mm)
 Hand held weight - 8.00 lbs. (3.62 kg)
 Entire tool weight - 8.00 lbs. (3.62 kg)
 Pull load - 2,650 lbs. (11.79 kN)

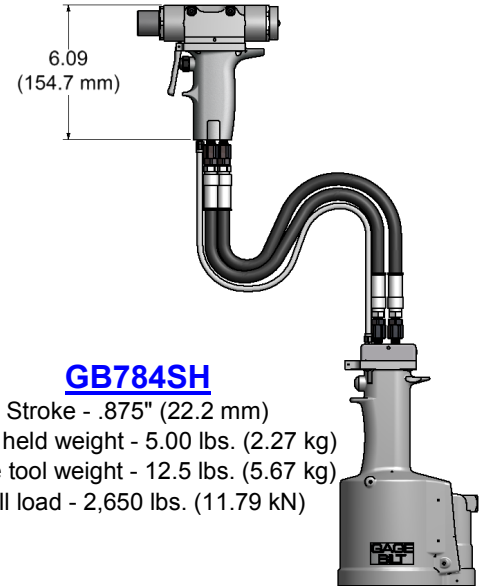
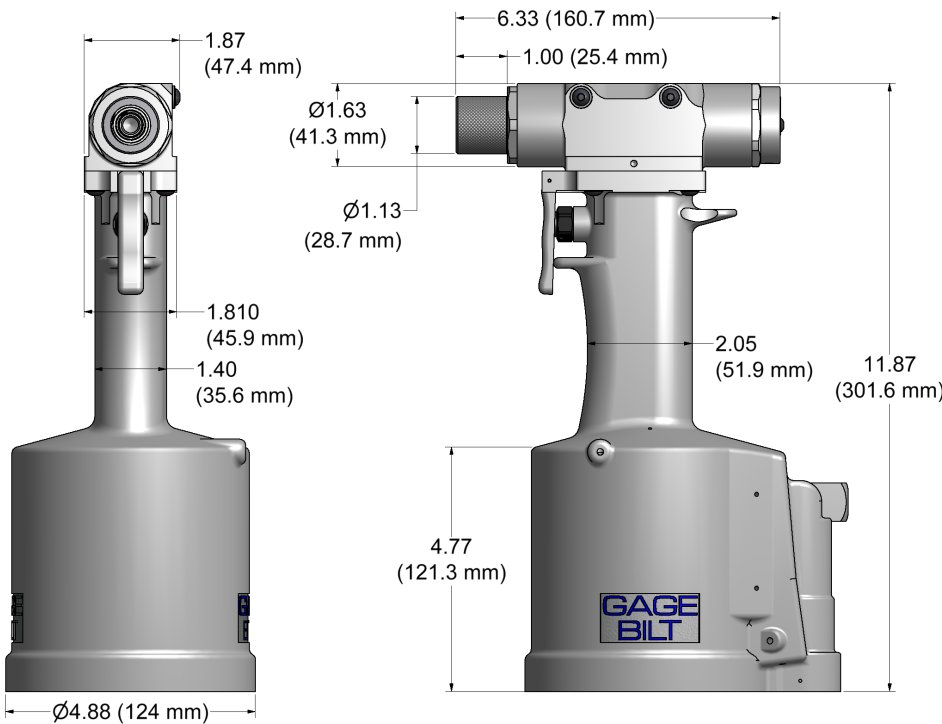

GB784SH

Stroke - .875" (22.2 mm)
 Hand held weight - 5.00 lbs. (2.27 kg)
 Entire tool weight - 12.5 lbs. (5.67 kg)
 Pull load - 2,650 lbs. (11.79 kN)



GB784SR

Stroke - .875" (22.2 mm)
 Hand held weight - 3.00 lbs. (1.4 kg)
 Entire tool weight - 9.00 lbs. (4.10 kg)
 Pull load - 2,650 lbs. (11.79 kN)

DESCRIPTION

The GB784 is a pneumatic-hydraulic tool designed specifically for the efficient installation of 2000 series Cherrylock® rivets NAS1398, NAS1399, NAS1738 and NAS1739. The GB784 weighs only 8 lbs. (3.6 kg) and can be operated in any position. It has a .875" (22.23mm) rivet setting stroke and a rated pull load of 2,650 lbs. (11.79 kN) with 90 psi. (6.9 bar) air pressure at the air inlet.

The GB784SH and GB784SR riveters offer a unique "split" system providing the operator with an ergonomic tool with reduced hand held weight, as shown above. The GB784SH comes with 8 feet (2.4 m) of hose and the GB784SR comes with 3 feet (.91 m) of hose.

The GB784 series riveters operate on 90 to 100 psi. (6.2-6.9 bar) of air pressure with 90 psi. (6.2 bar) providing the maximum efficiency. At 90 psi (6.2 bar) of air pressure, the GB784 series does not exceed 81.5 dB(A) and consumes .30 SFC/cycle (8.50 L/cycle).

The air inlet is provided with a 1/4-18 female pipe thread to accept the users air hose fitting.

NOSE ASSEMBLIES ARE NOT FURNISHED WITH THE TOOL AND MUST BE ORDERED SEPARATELY.



44766 Centre Court Clinton Twp. MI 48038 USA
 Ph: +1 (586) 226-1500 Fax: +1 (586) 226-1505
solutions@gagebilt.com / www.gagebilt.com

ACCESSORIES

(Sold Separately)

NOSE ASSEMBLY SELECTION CHART

681 PULLING HEADS FOR 2000 SERIES CHERRYLOCK® RIVETS CONFORMING TO NAS 1400 & NAS 1740

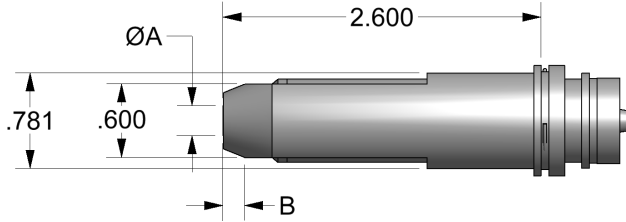

RIVET DIAMETER	NOSE ASSEMBLY	DIMENSION	
		A	B
3/32"	3U-681-25	.188	.348
3/32"	3C-681-25	.163	.332
1/8"	4U-681-25	.250	.341
1/8"	4C-681-25	.208	.377
5/32"	5U-681-25	.313	.377
5/32"	5C-681-25	.269	.352
3/16"	6U-681-25	.375	.418
3/16"	6C-681-25	.335	.386
1/4"	8U-681-25	.500	.452
1/4"	8C-681-25	.458	.398

GAGE BILT TOOL	STANDARD CHERRYLOCK® (NAS1398/99 & HS4464 & HS5413)							
	NOSE ASSEMBLY	RIVET DIAMETER	ALUMINUM		MONEL		STAINLESS	
			2163	2162	2563	2562	2643	2642
			2263	2262			2653	2652
		UNIV. HEAD	CTSK. HEAD	UNIV. HEAD	CTSK. HEAD	UNIV. HEAD	CTSK. HEAD	
GB784	XX-681-25	-4	ALL	ALL	ALL	ALL	ALL	ALL
		-5	8**	8**	8**	9**	8**	9**
		-6	8**	8**	8**	9**	8**	9**
		-8	8**	8**	8**	9**	-	-

GAGE BILT TOOL	BULBED CHERRYLOCK® (NAS1738/39)					
	NOSE ASSEMBLY	RIVET DIAMETER	ALUMINUM		MONEL	
			2239	2238	2539	2538
			2249	2248		
		UNIV. HEAD	CTSK. HEAD	UNIV. HEAD	CTSK. HEAD	
GB784	XX-681-25	-4	ALL *	ALL *	ALL *	ALL *
		-5	ALL *	ALL *	ALL *	ALL *
		-6	ALL *	ALL *	ALL *	ALL **

*May require 95 PSI at tool.

**Indicates maximum grip

GB784RK-1 Riveter Kit
(Equivalent to G784CLRB)



GB784RK Riveter Kit
(Equivalent to G784CLRA)

